

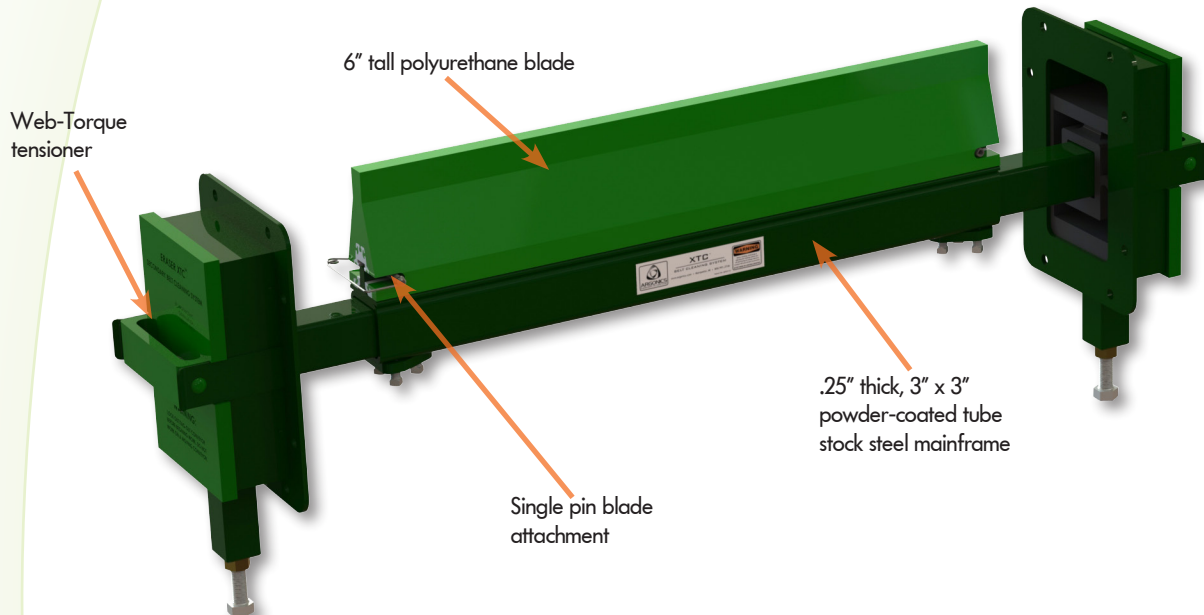







The XTC is one powerful reversing conveyor cleaner. Choose from polyurethane or tungsten carbide blades. The system can handle wet, dry, sticky or slimy conditions. The unique Web Torque™ tensioner has enough give for mechanical splices and the flow-over blade design reduces material build-up. The XTC is designed with the same toughness and durability as our standard Eraser, with a .25" (6 mm) thick, 3" x 3" (76 mm x 76 mm) tube stock steel mainframe and heavy duty stub ends.



BENEFITS

- Specifically designed for reversing conveyor belt applications
- Cleaning edges available in polyurethane and tungsten carbide
- The Web Torque™ shock absorbs the high level of impact and contortion which are present in most reversing applications
- No rusty springs, hoses, cables, shocks or mud-packed components to deal with
- Single pin blade attachment means quick blade change out, less downtime and no rusty bolts

BLADES

	N62 Ether Normally used for extremely wet applications, sands & fines		B93 Ester Our high temperature cleaning blade, up to 250°F (121°C)
	R80 Ether Good for wet applications with any pH level		FO83 Ester MSHA approved, Frontline® Flame-resistant cleaning blade
	G83 Ester Our standard, high abrasion-resistant all-purpose blade		RU83 Ester Flame-retardant, anti-static cleaning blade
	U90 Good for dry applications with any pH level		Tungsten/Steel Tip Good for wet, sticky, or caked-on materials, up to 400°F (203°C)



SIZING INFORMATION

Dimensions - in. (mm)

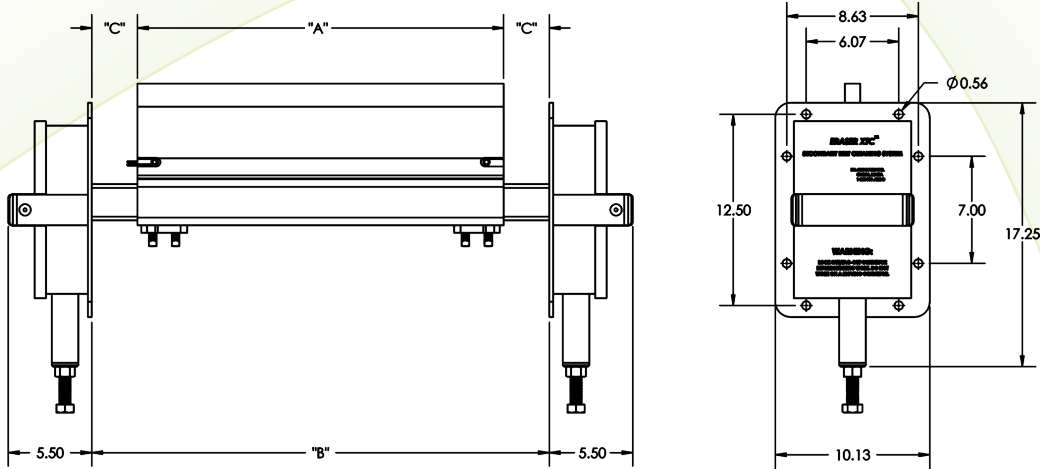

Part Number	A		Min B.		Max B.		Min C.		Max C.		Shipping Weight	
	inches	(mm)	inches	(mm)	inches	(mm)	inches	(mm)	inches	(mm)	lbs	(kg)
CP-XTC30D-G83	30.00	(762)	32.75	(832)	51.50	(1308)	0.25	(6)	10.75	(273)	137.00	(62)
CP-XTC36D-G83	36.00	(914)	38.75	(984)	57.50	(1461)	0.25	(6)	10.75	(273)	147.00	(67)
CP-XTC42D-G83	42.00	(1067)	44.75	(1137)	63.50	(1613)	0.25	(6)	10.75	(273)	156.00	(71)
CP-XTC48D-G83	48.00	(1219)	50.75	(1289)	69.50	(1765)	0.25	(6)	10.75	(273)	166.00	(75)
CP-XTC54D-G83	54.00	(1372)	56.75	(1441)	75.50	(1918)	0.25	(6)	10.75	(273)	175.00	(79)
CP-XTC60D-G83	60.00	(1524)	81.50	(2070)	86.75	(2203)	0.25	(6)	10.75	(273)	185.00	(84)

NOTES:

- For extended stub ends add 6" (152 mm) to B max. and 12" (305 mm) to C max.
- Standard sizes shown above. Other sizes are available from 18" (457 mm) to 96" (2438 mm).

SPECIFICATIONS

Recommended Belt Speeds

Urethane Blade: 0 - 500 fpm (2.54 m/s)

Tungsten Blade: 0 - 1000 fpm (5.08 m/s)

Mounting Distance

Vertical: 14.62" ± .25 (371 mm ± 6)

Horizontal: up to 16" (406 mm)

NOMENCLATURE

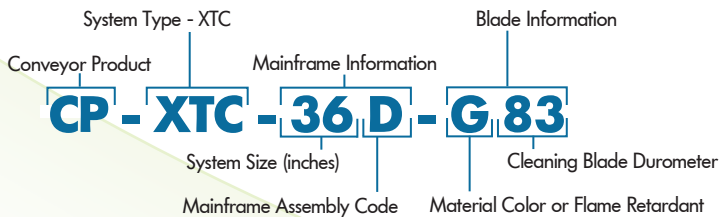

Notes:

- Tungsten system does not follow this nomenclature. Please contact your Argonics rep. for more information.

MOUNTING INFORMATION

